

The new C-Class



Mercedes-Benz
The best or nothing.



The Best knows no alternative. The new C-Class. World Car Of The Year.

The best knows no alternative and has won across the length and breadth of the world.

The C-Class has been voted the World Car of the Year for 2015 from among 24 fierce competitors.

The jurors observed, “the C-Class is the best in design, technology and delivers levels of refinement, luxury, safety, ride and handling that challenge the best-in-class”.





*Please read the disclaimer

2

3



*Please read the disclaimer





Luminous figure.

A design which has no peer. A face which is a Mercedes-Benz through and through. Elegant, clear lines as an expression of refined sportiness. And everything appears in a new light. Attractively fine when it lights up even during the daytime.

Impressive to the end.

*Please read the disclaimer



Nowhere is the athleticism more apparent than in the wide rear end. It's as if the new C-Class can't wait to get out of the starting blocks, with tail lights that follow the shoulder line and further emphasise the saloon's sportiness. Visually stunning LED lights add a contemporary touch with their modern interpretation and unmistakable design.



*Please read the disclaimer

Follows one thing only: your standards.

The new C-Class also stands for an attitude: it needs no attention – but pays all the more attention. Its innovative and foresighted systems keep track of everything and if necessary it reminds you when calmness could turn into drowsiness. It is totally without fuss and effortlessly superior.



Indulge your senses.

*Please read the disclaimer

Touchpad

Gestures are the original form of communication. They are brief and unambiguous. As if made for motoring. Because one thing above all deserves your attention whilst you're driving: the traffic around you. The touchpad with multitouch sensor system is an integral component of the Infotainment system. One or two gestures with your fingers – a quick swipe or splay – are all it needs to understand what you want. It can even decipher the letters and numbers traced on the touchpad. Incidentally, the touchpad in the new C-Class is the first ever to be able to control all the functions of an infotainment system based on gestures alone.



*Please read the disclaimer.

The internet has changed the way we live. Now it's also changing the way we drive.

Mercedes-Benz Connect essentially means networking between car and internet. Used in conjunction with the Infotainment system with touchpad, it opens up new and exciting possibilities.

INFOTAINMENT HIGHLIGHTS AT A GLANCE

Infotainment system with touchpad. This multimedia system combines entertainment, information and communication: Infotainment system with touchpad, internet capability, radio, twin tuner and CD player also allows networking with mobile devices via Bluetooth®.



What makes a car a Mercedes?

Tradition obliges: in our case the obligation is to innovate. We've gone along previously untravelled roads. Setting milestone after milestone. The First Car. First car with a crumple zone, the first ABS, the first diesel car. And whilst it's nice to look back, we'd much rather look forward.

Mercedes-Benz Intelligent Drive – our vision of accident-free driving. We develop intelligent technologies that actively assist the driver and make driving tangibly easier. The sensors of the driving assistance and safety systems are linked intelligently. Potential hazardous situations are detected earlier than ever and consequently avoided with increasing regularity.

BlueEfficiency – our vision of emission-free driving. Sustainability is a big word. And it's a prime consideration in absolutely everything we do. From minimising the environmental impact of our production to ensuring systematic lightweight construction and developing alternative drive concepts.

The aims are ambitious as you can see. But what could be better than seeing these aims achieved whilst on a long drive in a Mercedes?



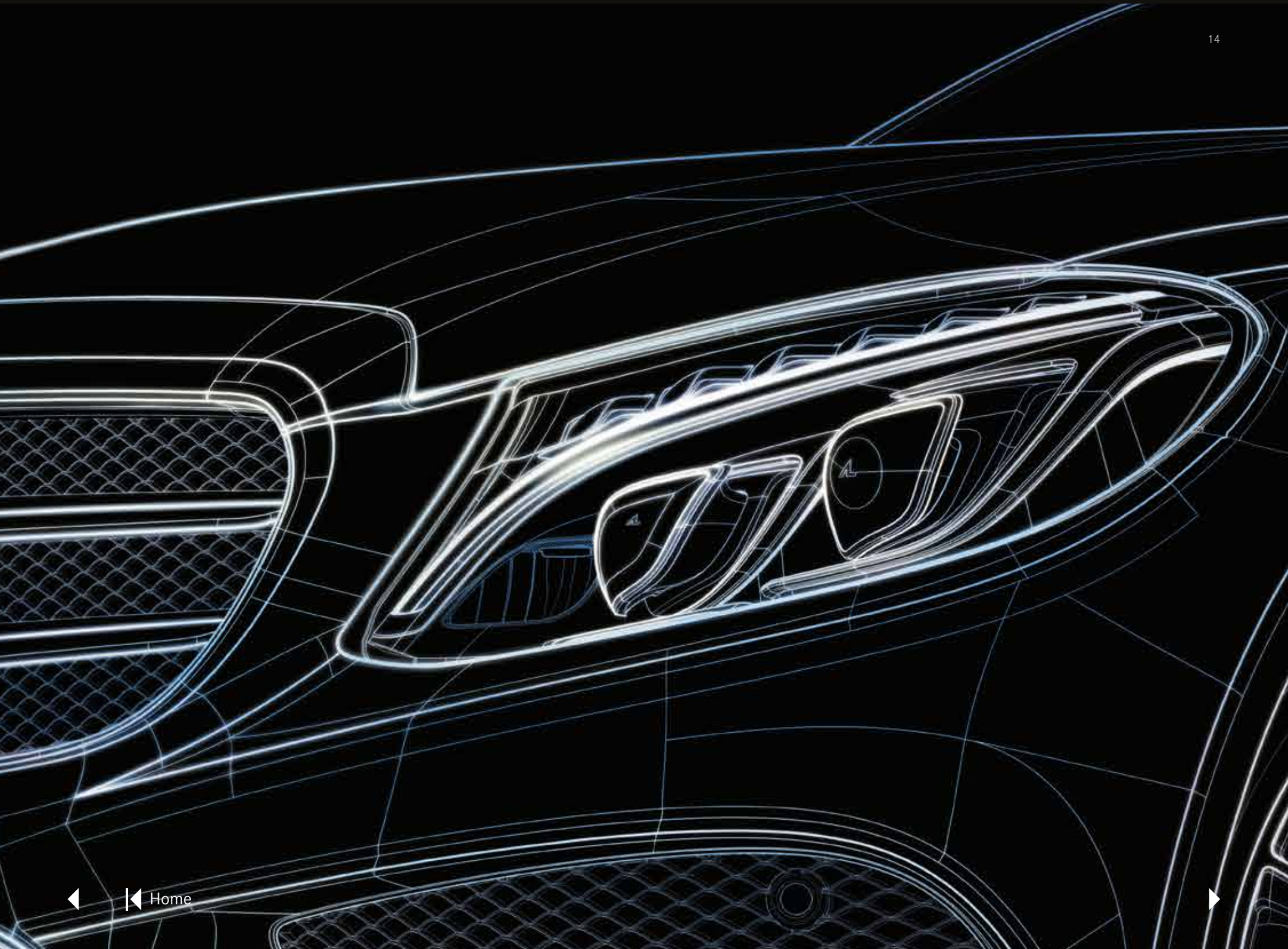

Energy needs change. And somebody to change it.

Petrol Engine

Design. The Crankcase is die-casted in aluminium and the cast cylinder head is made from high-strength aluminium alloy. The hollow-case crankshaft reduces weight, with four/eight counterweights and the balance shaft in lower part of crankcase to reduce free secondary. The single-pipe turbocharger is resistant up to 1050° C as there is a module welded to the exhaust manifold on the exhaust side. A high-pressure pump in the form of a single-plunger pump with a pressure and flow control valve is integrated into the pump module.

Mixture formation. The homogeneous/stratified direct injection with high-pressure rail enables injection pressure of up to 200 bar. The optimised valve timing comes with variable camshaft adjustment and also camshaft adjuster for the intake and exhaust valves. The mechanical adjustments of valve lift at speeds over 4000 rpm enables early closing of the intake valves for optimum cylinder charging and low gas cycle losses. Multiple fuel injections are aided with fast-responding piezo injectors centrally positioned in the combustion chamber. There is fantastic combination of direct injection with turbocharging. There is also improved Mercedes-Benz spray-guided combustion process and demand-controlled multi-spark ignition. For higher combustion speed, there is charged rotation vertical to the cylinder axis (tumbling effect) for higher combustion speed. To control the pressure in the turbocharger, there is a charged pressure control valve and air recirculation function as well.

Petrol:

C 200 petrol engine generates a maximum output of 135 kW (184 hp) and a peak torque of 300 Nm

Note: Not conducive for driving in Waterlogged roads with still water depth more than 25 cm.



Diesel Engine

Design. The compact, low design made possible by the rear-mounted camshaft drive also helps the vehicle to meet legal requirements in terms of pedestrian protection.

Mixture formation. The common-rail direct injection system enables a system pressure of up to 2050 bar. Indirect nozzle needle control creates the conditions for highly flexible injection timing and smooth engine operation, as well as a high output combined with low fuel consumption and emissions.

The geometry of the shallow combustion chamber design and a low compression ratio minimise untreated emissions, especially of NOx. The maximum ignition pressure of up to 200 bar contributes to a high output and low pollutant emissions.

The compact two-stage charger module consists of a small high-pressure and a large low-pressure turbocharger. Each of these comprises a turbine and a compressor driven by the turbine, connected to each other in series. The supply of combustion air is controlled to meet demand with the help of the two turbochargers. This leads to better cylinder charging, meaning more powerful torque even at low engine speeds.

Diesel:

C 220 CDI diesel engine generates a maximum output of 125 kW (170 hp) and a peak torque of 400 Nm

Note: Not conducive for driving in Waterlogged roads with still water depth more than 25 cm.



7G-TRONIC PLUS. The command centre.

In addition to seven gears, the 7-speed automatic transmission offers excellent ride comfort, driving enjoyment and efficiency. The seven forward gears allow a wide ratio spread with low engine speed increments between the individual gears. The result: quick, smooth and fuel-saving gear changes every time. Skipping individual gears allows multiple downshifts for powerful, fast bursts of speed. And the **Drive mode selector (AGILITY SELECT driving experience switch)** lets the driver preselect the gearshift characteristics. As in motorsport, the driver can change gear using the steering-wheel gearshift paddles.

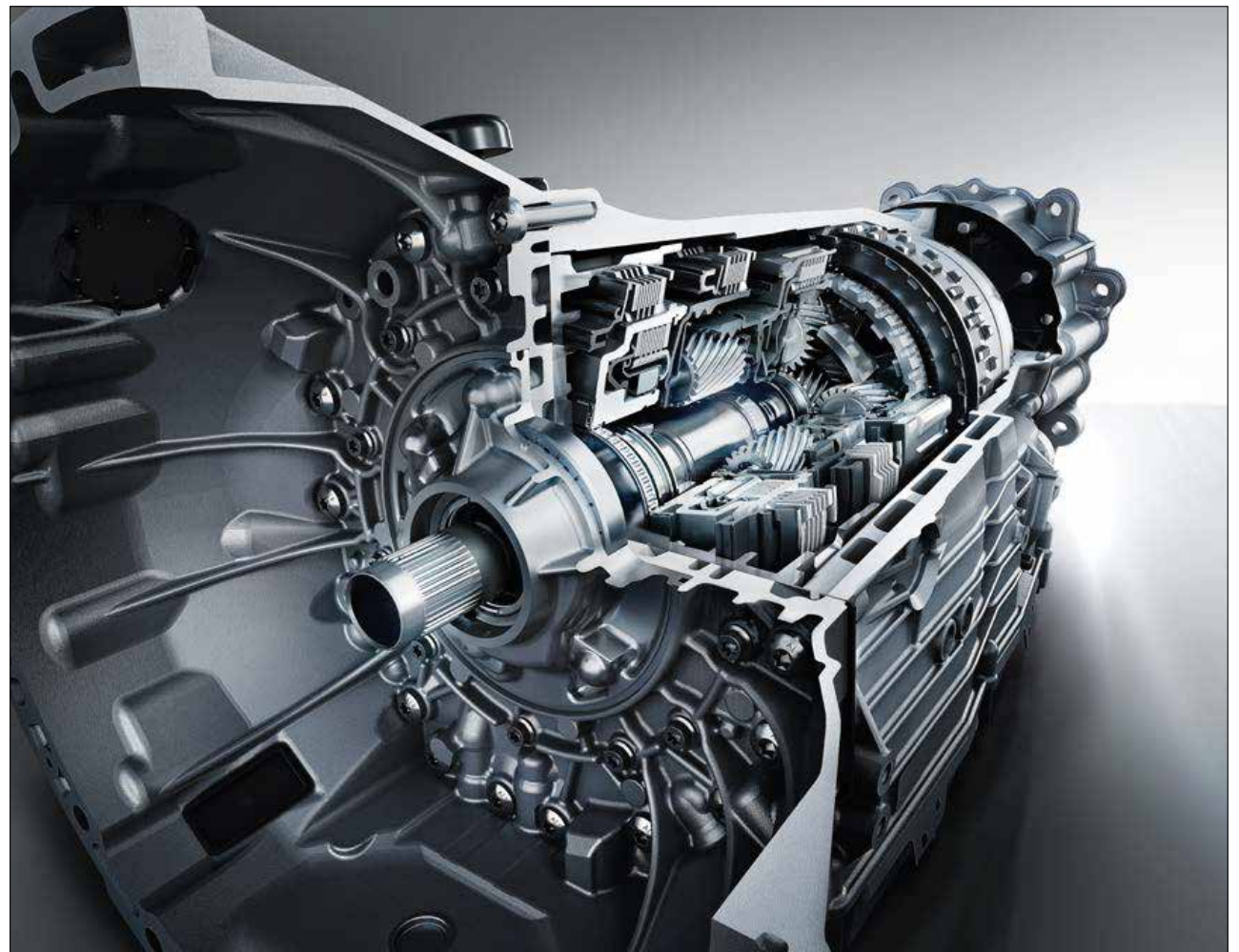

Visibly more feeling

The Interior Light package creates a pleasant atmosphere inside the new C-Class. Thanks to discreet indirect illumination of the footwells and the handle recesses, and illuminated elements in the centre console. A practical rear reading lamp is built into the grab handle. Plus there are exit and warning lights in all the doors to enhance visibility and safety.



*Please read the disclaimer.

Drive mode selector (AGILITY SELECT driving experience switch)

At a touch of the AGILITY SELECT feature, drivers can choose between comfortable, sporty, particularly sporty and efficient driving styles, or their own individually defined style. Parameters such as the engine, transmission and steering characteristics are adjusted according to the selected transmission mode.

- 5 transmission mode can be selected via AGILITY SELECT: “Economy”, “Comfort”, “Sport”, “Sport+” or “Individual”
- Standard setting “Comfort”: well-balanced and fuel-efficient
- “Eco” mode: keeping fuel consumption as low as possible
- “Sport” mode: added agility and dynamism thanks to a more direct characteristic steering curve, spontaneous throttle response and modified shift points
- “Sport+” mode: further enhanced sportiness and drive system are even more dynamically tuned
- “Individual” mode: individual parameters can be varied as required, using the Controller and the configuration menu in the head unit
- Short-term M mode after using the steering-wheel gearshift paddles: automatic change back from “Manual” into the last selected AGILITY SELECT transmission mode after a defined period of time
- Confirmation of the selection made is displayed in both the instrument cluster and the head unit
- Multiple downshifts for fast sprints



*Please read the disclaimer.

Multimedia system Audio 20 CD with Touchpad

Sit back and enjoy your drive. As you keep your eye on the road, you can be rest assured that your enjoyment and communication is well taken care of. Thanks to the advanced multimedia system. Experience a unique combination that fuses the Audio 20 CD with touchpad, optional navigation, twin tuner and CD player that allows networking with mobile devices via Bluetooth®. Connecting to Mercedes-Benz Radio App is easy as well.



*Please read the disclaimer.

Fascinating, elegant, intelligent

The **LED High Performance headlamps** enhance safety at night by distributing the light over a wide area with a light colour similar to daylight.

Reverse camera with dynamic guiding lines The reversing camera is an optical parking aid. It shows the area behind your vehicle in the infotainment system display. It comes with a motorised lens cover and in two kinds of display modes – normal and wide view.



A climate with a special feel

With its large glass surfaces, the **panoramic sliding sunroof** (Available in C 200 and C 220 CDI AVANTGARDE) creates an exceptionally light and friendly ambience. It consists of a fixed glass roof at the rear and an electrically operated sliding glass roof at the front. Two electrically operated sunblinds offer shade in bright sunlight. In the raised position, the glass roof automatically adjusts in three stages to suit the current vehicle speed. The glass roof is lowered at high speeds. The noise level and air circulation in the interior are reduced. Conversely, it raises itself again at low speeds.

THE PERFECT TEMPERATURE FOR ANY TEMPERAMENT

The **THERMATIC** automatic climate control with 2 climate zones – offers individual climate comfort for the driver and front passenger. Temperature and airflow can be adjusted separately for each side. The air is automatically cooled or heated in each case depending on the selected setting.



Extravagant. The AVANTGARDE design and equipment line.

The expressive nature of the new C-Class 200 & 220 CDI AVANTGARDE is immediately obvious. It is remarkably different and unique, featuring chrome inserts and a chromed trim.

Highlights - Exterior

LED High Performance headlamps with integral daytime running lamps and fog lamp function

Panoramic sliding sunroof

Rear bumper with insert in black diffuser-look grain finish

Suspension with higher ground clearance

Mirror Package – electrically folding mirrors and automatically dimming exterior driver’s mirror and rear-view mirror

Highlights - Interior

Drive mode selector (AGILITY SELECT) to select 5 different driving modes

Steering wheel with gear shift paddles

Front door sill panels with ‘Mercedes-Benz’ lettering

Front seats in ‘Cobra-look’ – electrically adjustable

Interior Lighting Package

High gloss brown burr walnut wood trim

Upholstery, ARTICO leather (black/black or silk beige/black)

Automatic climate control THERMATIC – two zone

KEYLESS GO starting function

Reversing camera

ADAPTIVE BRAKE with Hill-Start Assist, priming and brake drying in the wet

7 Airbags

ATTENTION ASSIST

Audio 20 CD with touchpad: Multimedia system with high-resolution 17.78 cm colour display



*Please read the disclaimer.

Confidently stylish. The STYLE design and equipment line.

Electric sliding sunroof

7G-TRONIC PLUS automatic transmission including DIRECT SELECT lever on steering wheel

AGILITY CONTROL suspension with selective damping system

Drive mode selector (AGILITY SELECT) to select 5 different transmission modes and adjust parameters such as engine, A/C and steering characteristics

ECO start/stop function

LED High Performance headlamps with integral daytime running lamps and fog lamp function

Steering wheel with gear shift paddles

3-spoke multi-function steering wheel – controls audio and onboard settings

Folding rear seat backrests 40/20/40 split, including armrest with double cup holder and stowage compartment

Front seats in 'Cobra-look' – electrically adjustable

Instrument cluster with two tube-design round dials and 13.97 cm TFT multi-function display

Interior Lighting Package

Automatic climate control THERMATIC – two zone

Reversing camera

Audio 20 CD with touchpad: Multimedia system with high-resolution 17.78 cm colour display



*Please read the disclaimer.

The great feeling of driving a Mercedes-Benz

Mercedes-Benz was the world's first automotive manufacturer to develop an integral safety concept. To prevent accidents, react as effectively as possible to danger and mitigate the consequences of accidents. Not only for those sitting inside a Mercedes but also for all other road users.

Safe driving: ATTENTION ASSIST

This drowsiness detection system can be useful on long trips in particular. Between 60 and 200 km/h sensors analyse driving behaviour and can detect deviations from a previously determined, individual driver profile, enabling timely alerts in the event of serious lapses in concentration or drowsiness. A dedicated menu in the instrument cluster provides the driver with additional information.



ATTENTION ASSIST

In the event of danger: PRE-SAFE® anticipatory occupant protection system

The preventive occupant protection system is able to recognise critical driving situations in advance and, as a precaution, it can activate safety systems. This is based on PRE-SAFE® continuously monitoring sensor data from systems like the ESP® and BAS, and can thus, for example, analyse driving situations such as oversteer/ understeer as well as emergency braking. If a critical driving situation is detected, in fractions

of seconds the belts on the front seats can be reversibly tensioned and the side windows automatically closed, so that the belts and airbags are able to deploy their full protective effect should an impact occur.

In an accident: airbags. 3-point seat belts, belt tensioners, belt-force limiters and airbags are optimally coordinated with each other. Seven airbags can all help to prevent injuries. In order to protect the occupants two adaptive front airbags are installed, which are deployed depending on the

severity of the accident. What's more, there are sidebags fitted in the front seats, and two large windowbags are also integrated.

In an accident: NECK-PRO® head restraints.

The NECK-PRO® head restraints for the driver and front passenger can be activated in a rear impact: a spring mechanism moves the head restraints forwards and upwards; the head can thus be supported earlier and the strain on the spine can be reduced.

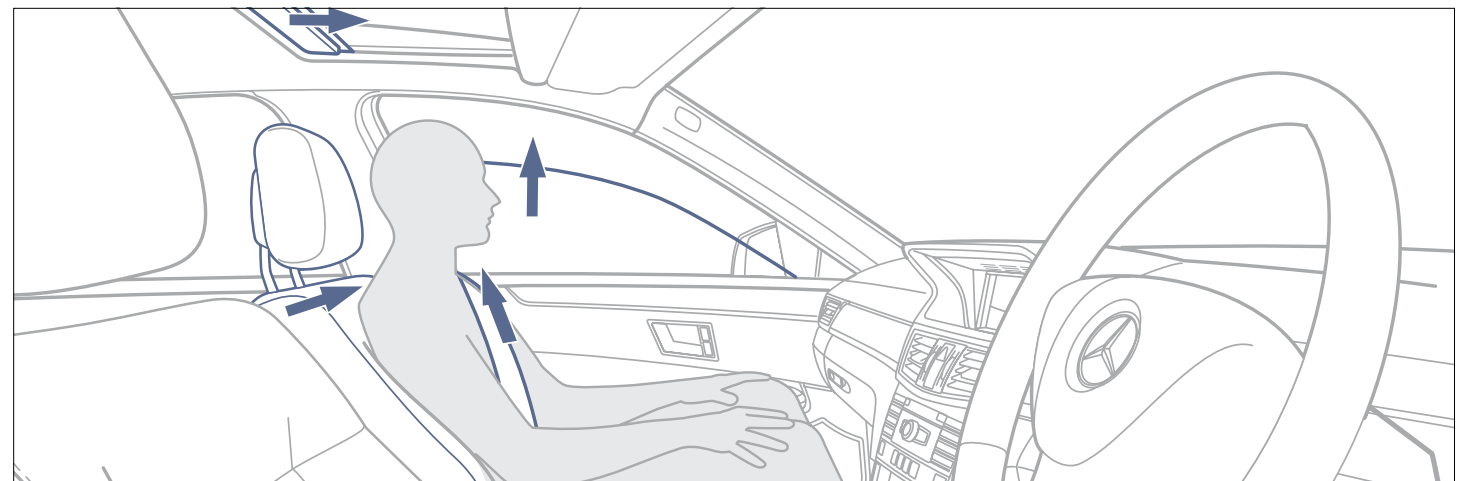

The PRE-SAFE® anticipatory occupant protection system can recognise critical driving situations and initiate measures to protect the occupants.

On the road to accident-free driving. Mercedes-Benz Intelligent Drive.

Measures after an accident.

In order to reduce consequential damage and, where necessary, to support the rescue of the occupants, Mercedes-Benz has developed further measures. These include the automatic engine cut-off or the activation of the hazard warning lamps and the emergency interior lighting. The central locking also opens automatically, and crash joints between the door and the wing make it easier to open the doors after an accident.

Supplemental Restraint System (SRS)

This feature offers additional protection by performing a range of protective functions.

- Deploys airbags selectively
- Deploys NECK-PRO®
- Tensions seat belts
- Switches off engine and heating
- Unlocks doors
- Lowers side windows by 50 mm
- Activates hazard warning lamps
- Triggers pyrofuse in the fuse box
- Activates crash responsive emergency lighting

There can hardly be a safer place on the planet than inside the new C-Class. This is ensured by Mercedes-Benz Intelligent Drive. It links countless systems like PRE-SAFE®,

BAS, ESP®, ASR, 7 airbags, Electric parking brake, Hill start assist and lots more so you are safer on the road in the new C-Class.



The World Car of the Year, now racing with 510 horses.
The new Mercedes-AMG C 63 S

A power-soaked 4.0 litres V8 Bi-Turbo Engine defines the new generation Mercedes-AMG C 63 S. Its sporty rear-wheel drive and roaring 0-100 in 4 seconds makes it an unparalleled performance artiste. For that sheer Ah My God feeling, from the World Car of the Year.



*Please read the disclaimer



*Please read the disclaimer

The only thing that can follow it: its call.

Centrifugal force tamed: Where driving dynamics are concerned, there is innovation after innovation in the Mercedes-AMG C 63 S. And they are literally in your hands thanks to the AMG DYNAMIC SELECT Switch - the AMG RIDE CONTROL sports suspension with adjustable adaptive damping in three stages, two dynamic engine mounts and the electronic rear axle differential lock defer completely to your demands - from extremely sporty to pleasantly comfortable. And because, with five characterful transmission modes, it can be difficult to decide on one of them, make it easy for yourself: simply follow your instinct. Or its call.

Vehicle of innovation. Literally speaking.

In strong form: this is how the Mercedes-AMG C 63 S presents itself. In its AMG 4.0-litre V8 biturbo engine eight cylinders persistently pump their hearts out. One step on the accelerator and you understand why the passenger compartment is called a cockpit: in 4 seconds from 0 to 100 km/h – that is no longer acceleration; it declares war on the laws of physics. And as befits a true AMG, the exterior leaves only one thing to be desired when it comes to looks and function: climb in immediately and put this 375 kW (510 hp) strong power package on the road.



*Please read the disclaimer.



*Please read the disclaimer.

Mercedes-AMG C 63 S exterior

The Mercedes-AMG C 63 S appears as predatory as a beast with its low radiator grille, powerdomes on the bonnet and twin louvre on the front apron: always ready for the next sprint through its territory – the roads of this world.

Sportiness taken to the limit: the Mercedes-AMG C 63 S. With the AMG 4.0-litre V8 engine, 375 kW (510 hp) and 700 Nm the saloon accomplishes the feat of 0 to 100 km/h in 4.0 seconds and new standards are set for driving dynamics too: the electronically controlled AMG rear axle differential lock improves both traction and driving stability. Not only does this benefit agility and motoring pleasure – vehicle handling also becomes noticeably more precise.

Exterior Highlights

Dynamic AMG engine mounts

AMG radiator grille with silver-chrome twin louvre and “AMG” lettering

AMG performance exhaust

LED Intelligent Light System

AMG front wing with “V8 BITURBO” lettering

AMG side sill panels

48.3 cm (19-inch) AMG cross-spoke light-alloy wheels painted in matt black and with high-sheen rim flange (optional)



*Please read the disclaimer.





*Please read the disclaimer.



Mercedes-AMG C 63 S interior

The interior of the Mercedes-AMG C 63 S lives up to what its exterior promises – pure sportiness, coupled with excellent design.

The interior of the Mercedes-AMG C 63 S is loaded with exclusive highlights, equipment and appointments like the centre console with an IWC design analogue clock.

For an even better grip during sporty manoeuvres, the grip area on the AMG performance steering wheel in Nappa Leather is lined with DINAMICA microfibre. Coloured topstitching and coloured 12 o'clock marking completing the sporty design.

Interior Highlights

AMG DYNAMIC SELECT switch to select the AMG transmission modes Comfort, Sport, Sport+, Race and Individual

AMG carbon-fibre / light longitudinal-grain aluminium trim consisting of carbon-fibre trim in the centre console and light longitudinal-grain aluminium trim in the dashboard and in the doors (Optional)

AMG Performance steering wheel in black Nappa Leather/DINAMICA microfibre with coloured contrasting topstitching and coloured 12 o'clock markings

AMG Nappa Leather Black upholstery

AMG Nappa Leather Platinum white pearl upholstery

AMG Nappa Leather Red pepper/Black upholstery

Burmester® surround sound system with 13 speakers, a 9-channel DSP amplifier and a total output of 590 watts

Panoramic Sliding Sunroof

COMAND ONLINE with 6 DVD changer

Active Parking Assist with PARKTRONIC and Reversing Camera

Head-up Display



*Please read the disclaimer.

Mercedes-AMG C 63 S technical details

Performance, dynamism and efficiency – this is what the Mercedes-AMG C 63 S stands for. Its AMG 4.0-litre V8 biturbo engine comes from a completely new AMG engine generation and with a rated output of 375 kW (510 hp) and 700 Nm. The high-performance engine is built entirely by hand at the Affalterbach engine Manufaktur based on the traditional AMG “one man, one engine” philosophy – which is clearly evident on the AMG engine badge bearing the signature of the AMG technician responsible.

Highlights

AMG SPEEDSHIFT MCT 7-speed sports transmission with five transmission modes, double-declutching and Race Start function

AMG RIDE CONTROL sports suspension with adjustable adaptive damping

AMG mechanical rear axle differential lock

Dynamic AMG engine mounts



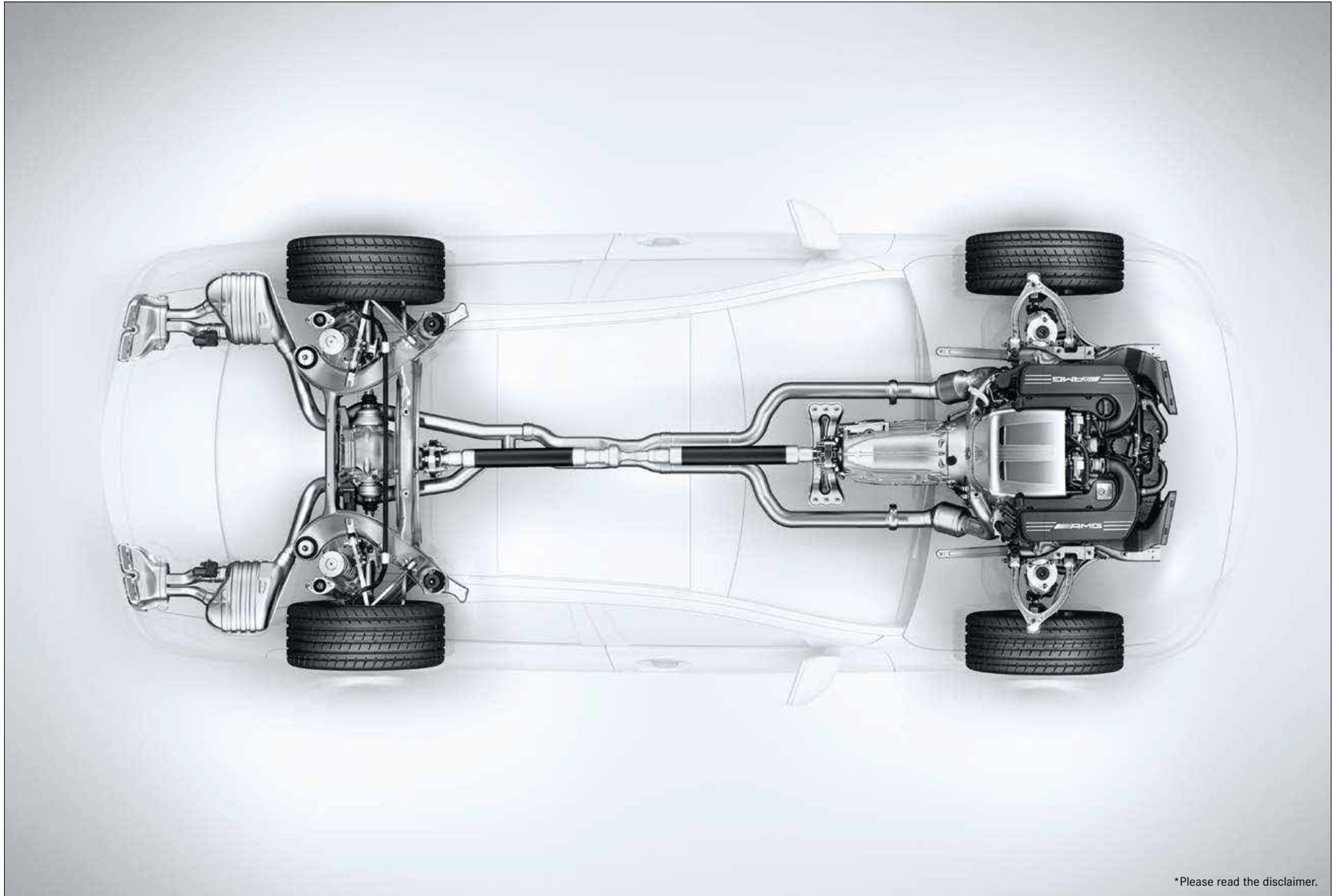

*Please read the disclaimer.



Mercedes-AMG C 63 S Packages

designo Luxury Package

Luxury Package 1 (Optional)

The exclusive interior in designo saddle brown Nappa Leather radiates stylish elegance. High-quality details such as the recurring diamond design with beige contrasting topstitching make the harmonious ambience an aesthetic eye-catcher.



Luxury Package 2 (Optional)

Another option under this package features a sporty and exclusive look with two-tone upholstery in designo Nappa Leather. It impresses with an exciting interplay between the colours platinum white pearl and black and high-quality details such as the diamond design, patterned perforations and contrasting topstitching.



*Please read the disclaimer.

Mercedes-AMG C 63 S Packages

Performance Package

AMG Carbon Exterior Package (Optional)

With sporty details in carbon fibre, this package brings a significant level of dynamism to the vehicle when viewed from any angle. The A-wing in the front apron and inserts in the side sill panels and above the rear diffuser are finished in carbon fibre.



AMG high performance ceramic composite braking system (Optional)

Extremely short stopping distances, precise pressure point and outstanding fade resistance even in extreme operating conditions – the AMG ceramic high-performance compound brake system offers racetrack braking performance accompanied by a reduction of weight of around 30% over standard brake discs.



Upholstery, trim and alloy - The new C-Class

UPHOLSTERY

ARTICO Leather Black

ARTICO Leather Silk Beige



TRIM

High-gloss brown burr walnut wood trim
(Available in C 200 and C 220 CDI AVANTGARDE)

Light Aluminium trim with longitudinal grain
(Available in C 220 CDI Style)



ALLOY WHEEL

43.2 cm (R 17) 5-twin-spoke light-alloy wheels
(Available in C 200 and C 220 CDI AVANTGARDE)

40.6 cm (R 16) multi-spoke light-alloy wheels painted in vanadium silver (220 CDI STYLE)



Paintwork - The new C-Class

METALLIC PAINTS

Obsidian Black

Iridium Silver

Palladium Silver

Cavansite Blue

Citrine Brown

NON-METALLIC PAINT

Polar White

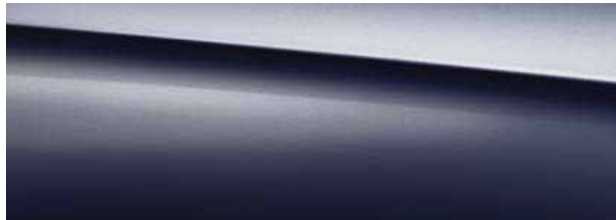
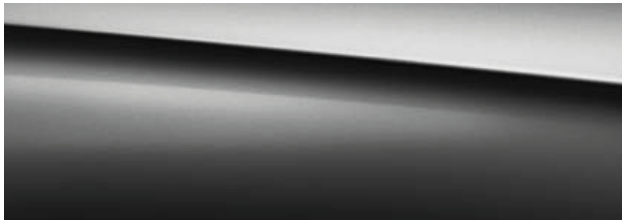

Upholstery, seat belt and trim - The new Mercedes-AMG C 63 S

UPHOLSTERY

AMG Nappa Leather Black upholstery

AMG Nappa Leather Platinum white pearl upholstery

AMG Nappa Leather Red pepper / Black upholstery



SEAT BELT

Red

Black

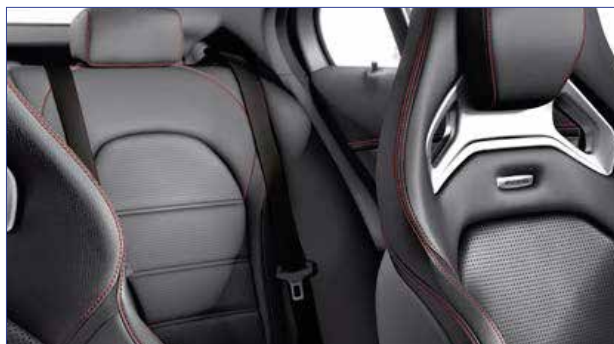
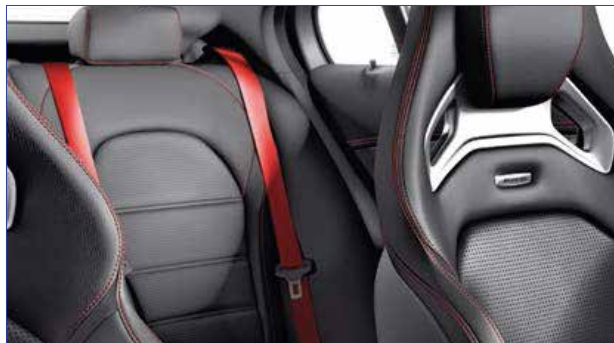

TRIM

AMG carbon-fibre / light longitudinal-grain aluminium trim

AMG matt silver glass-fibre trim / aluminium with light longitudinal-grain

Open Pore Ashwood black trim

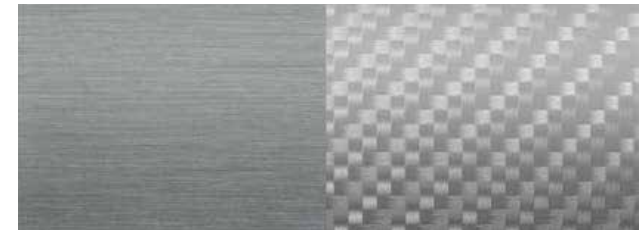
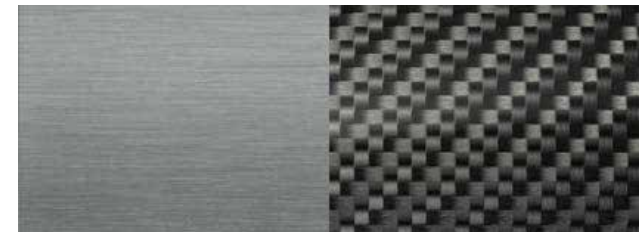

*Please read the disclaimer.



Paintwork and alloy - The new Mercedes-AMG C 63 S

PAINT

Polar White

Obsidian Black

Iridium Silver

Brilliant Blue

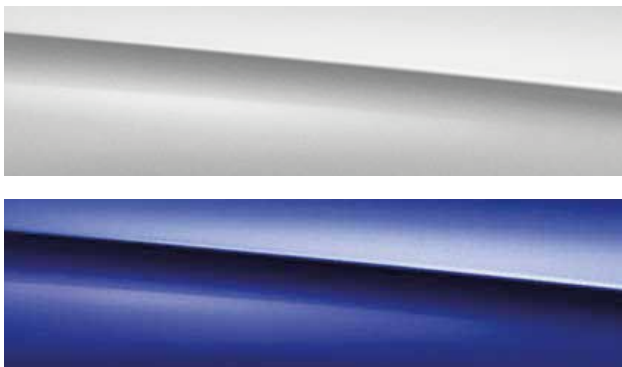
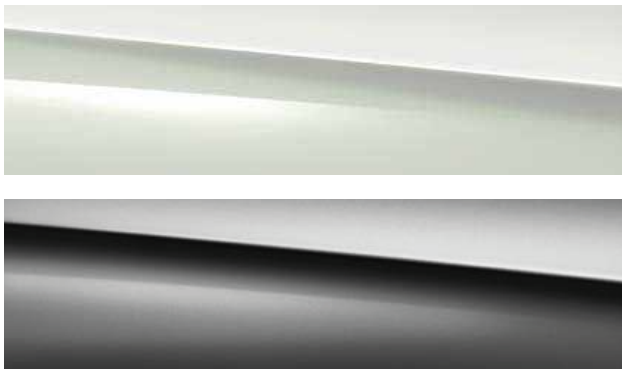

ALLOYS

48.3 cm (R19) AMG cross-spoke light alloy wheels in matt black

48.3 cm (R19) AMG cross-spoke light alloy wheels in titanium black

48.3 cm (R19) AMG 5-twin spoke alloy wheels painted in titanium grey



Genuine Accessories

Styling

Front Apron Spoiler Emphasises the width of the vehicle and lowers the visual focus at the front end. Made from dimensionally stable polyurethane, with high-quality primed finish. To be painted in required colour by your Mercedes-Benz dealership.

Roof spoiler Elongates the roof line and gives the rear of the vehicle a more dynamic and sporty look. Does not affect field of vision in rear-view mirror. High-quality primed finish allows product to be painted in required colour. Highly durable thanks to precision-fit, dimensionally stable polyurethane. Straightforward fitting – no need for additional drilling.

Rear Spoiler Discreet spoiler, fitted to the boot lid, subtly accentuating the rear contours of the Saloon. High-quality primed finish allows product to be painted in required colour.

Exterior mirror housing, set of 2, black Black, high-gloss Mercedes-Benz Sport Equipment exterior mirror housings for enhanced aerodynamics and an individual, sporty and dynamic look.



Front apron spoiler lip



Roof spoiler



Rear spoiler



High-gloss black exterior mirror housing

Illuminated Star Let your star shine. Thanks to fibre-optic cables and LED technology, the central star emblem in your Mercedes' radiator grille lights up when you remotely lock/unlock the vehicle or open the door or tailgate. Only functions when engine is switched off.

Chrome-design door handle recesses An exclusive highlight: the refined, chrome-design door handle recesses lend the vehicle a polished, individual look. The stable, robust material is precision-tailored to the bodywork and protects the paintwork in the recess from scratches.

Sports pedals For a sporty look – the pedal covers, in brushed stainless steel, add a sporty, high-quality touch to the interior. The genuine parts feature a non-slip rubber stud inlay and comply with Mercedes Benz's safety standards.

Garmin® MAP PILOT, navigation module SD card Turns your Audio 20 radio into a high-performance navigation system with 3D map display. Garmin® MAP PILOT uses the standard-fit 17.8 cm TFT colour display and can be operated conveniently using the vehicle's Controller and the Audio 20 keypad.



Illuminated Star



Chrome-design door handle recesses



Sports pedals



Garmin® MAP PILOT

Genuine Accessories

Comfort and Cargo

Universal hook, Style & Travel Equipment, black, plastic The head restraint elements are simple to fit and remove. The modular system centres around a base support which can be combined with various products – a coat hanger, a universal hook or a folding table.

Stowage crate A secure hold for items which are prone to tip over or slide around, e.g. shopping bags. Adjustable partitioning elements allow crate to be divided into max. four sections. Optimum functionality only in conjunction with shallow boot tub.

Shopping Crate Anthracite, collapsible. When not in use can be folded and stowed away in the boot compartment. Features Mercedes-Benz logo and lettering.

Luggage-securing feature This highly flexible, padded luggage-securing feature, with Mercedes-Benz lettering, helps create order in the boot/load compartment. Special Velcro fastenings provide a secure hold at the sides and prevent objects from sliding around during the average journey. The luggage-securing features are easy to use and can be combined to allow larger objects to be secured in place.

Concertina load sill protector Protects the rear of the car from scratches when you're loading the vehicle – and prevents dirt from the car from getting onto your clothes.

*Not suitable for velour or wooden load compartment floors. Velcro only adheres to Delours material (loop pile).



Universal hook



Stowage crate



Shopping Crate



Luggage-securing feature



Concertina load sill protector

Tie Down Straps A reliable accessory for your travels. The adjustable tie-down strap for everyday use on board. Designed to secure objects in place and prevent them from sliding around. During your journey, the tie-down strap prevents damage to the cargo and also prevents the occupants from being assailed by flying objects when the vehicle is braked. You'll be impressed every time at how easy it is to use. Always secure. Always at hand.

Luggage Net Mercedes-Benz luggage nets - for a tidy and uncluttered interior. Versatile and, once fitted, indispensable: the luggage nets are available in various sizes, most taking the form of a pocket. They are designed to secure small items and lightweight objects in place, preventing damage during transport. All-round flexibility: the black stretch nylon net hugs the contents and has a high capacity.

Boot tub, shallow, with through-loading facility The easy-care boot tub is even suitable for foodstuffs and liquids. The shape of the tub, with its slightly raised edge, is optimally tailored to the load area. Very robust - made from impact-resistant, non-split polypropylene.

Apple iPad2®-iPad4® Docking Stat., rear, kit This ergonomic, crashproof device introduces the iPad® and all of its familiar functions to your Mercedes-Benz. All connections, e.g. for your headphones or charging cable, remain accessible. The mount is fitted to the head restraint and can be tilted and rotated around 90°. Available for the iPad® 2, iPad® 3 and iPad® 4.



Tie Down Straps



Luggage Net



Boot tub



Apple iPad2®-iPad4® Docking Stat., rear, kit

Genuine Accessories

Protection

Mud Flaps The mud flaps protect the sides, rear and underbody of the vehicle from scratches and damage from loose chippings. They also help protect following traffic from loose chippings, splash water and dirt. And they minimize spray. Precision-tailored to the contours of the vehicle – do not affect the vehicle’s sporty looks. Material: extremely hard-wearing, durable, UV-resistant. Can be painted in the color of your choice.

Not in conjunction with AMG styling kit.

Floor Mats Mercedes Benz genuine floor mats have to undergo rigorous testing before they are deemed worthy of the star logo: durability, fade-resistant colour and a neutral odour. The mats are precision-tailored to your Mercedes-Benz using the vehicle’s original CAD data. Can be clip-fastened to the floor to prevent slipping. Floor Mats are available in various types and colors in order to meet your personal requirements.

Velour Floor Mats Elegant, high-quality, black tufted velour mats, featuring metal badge with Mercedes-Benz lettering. Available in various colors to match the interior of your car.

All-Season Floor Mats Robust, washable synthetic mats, designed for heavy use. Contemporary design with recessed areas and raised edge. With distinctive Mercedes-Benz star logo. Available in black.



Mud Flaps

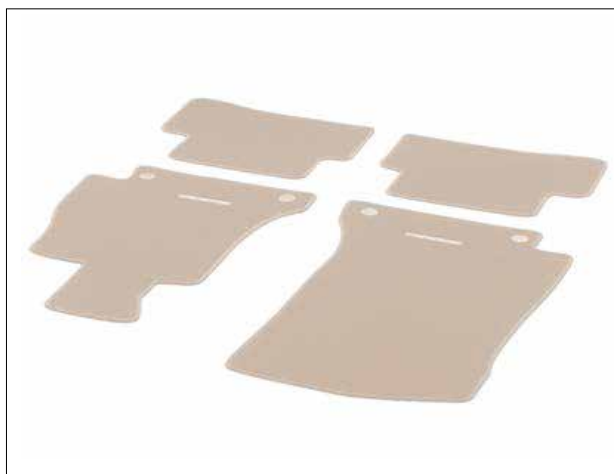

Velour Floor Mats

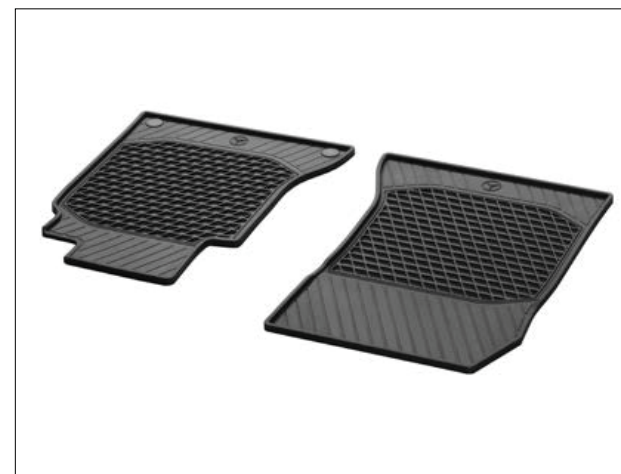

All-Season Floor Mats

Genuine Accessories

Alloy wheels

Mercedes-Benz light-alloy wheels not only boost your vehicle's looks, they also offer the ultimate in safety. All wheels are precision-tailored to your vehicle in terms of load profile and dimensions. Before your light-alloy wheels are allowed to accompany you safely on your travels, they are subjected to an extensive development and testing programme. Each wheel design has to pass a variety

of endurance tests, based on exacting Mercedes-Benz guidelines, all of which exceed statutory requirements. Only once all of the tests have been passed may the wheels be included in the range of genuine Mercedes-Benz light-alloy wheels. Add an individual touch to your vehicle with a tested and approved genuine Mercedes-Benz light-alloy wheel and head for the open road.

Hub Caps

Mercedes-Benz hub caps provides a stylish finish for light Alloy wheels. It is not just attractive but practical too as the caps keep the hubs clean. There are plenty of options available to choose from various designs available to suit Mercedes-Benz vehicles.



5-spoke wheel, 43.2 cm (R17), high-shine tremolite metallic
Tyre size : 225/50/R17



5-twin-spoke wheel, 43.2 cm (R17), high-shine black
Tyre size : 225/50/R17



Multi-spoke wheel, 43.2 cm (R17), vanadium silver
Tyre size : 225/50/R17



5-spoke wheel, 43.2 cm (R17), vanadium silver
Tyre size : 225/50/R17



Genuine Accessories

Protection

Valve caps Chrome valve caps with a Mercedes-Benz star logo embossed on head, add a refined stylish finishing touch to all Mercedes-Benz light alloy wheels.

Rim locks The coded key secures your wheel against theft.

Coolbox Not only cools but warms too. Cools to up to 20°C below ambient temperature – to max. -2°C. Can be switched to warming function. Robust, highly insulated hard case with fabric cover, outside pockets and padded shoulder strap. Capacity: 24 litres. Can be connected to 12 V socket in vehicle or to 230 V power source via separately available rectifier.

Rectifier Allows the coolbox to be connected to a 230 V socket at home.



Valve caps



Rim locks



Coolbox



Rectifier

Genuine Accessories

Mercedes-Benz Child Safety

Mercedes Benz child seats offer optimum protection in the event of an accident. Child seats are tested and inspected to exacting Mercedes-Benz specification.

“BABY-SAFE plus II” child seat Deep, moulded seat design offers extra side-impact protection for optimum safety. Special padding, designed to protect particularly vulnerable body areas of children up to around 15 months (up to 13 kg). Equipped as standard with automatic child seat recognition.

“DUO plus” child seat Optimum safety for children between the ages of around 8 months and 4 years (9 to 18 kg). Fitted as standard with top tether, an additional belt for securing the head section, a height-adjustable shoulder belt, ventilation channels and ISOFIX attachment points.

“KIDFIX” child seat Booster seat for optimum side-impact protection, with height adjustable backrest. The “KIDFIX” seat is secured using the 3-point seat belt and ISOFIX attachment points. For children between the ages of around 3.5 and 12 (15 to 36 kg).



“BABY-SAFE plus II” child seat



“DUO plus” child seat



“KIDFIX” child seat

Dimensions

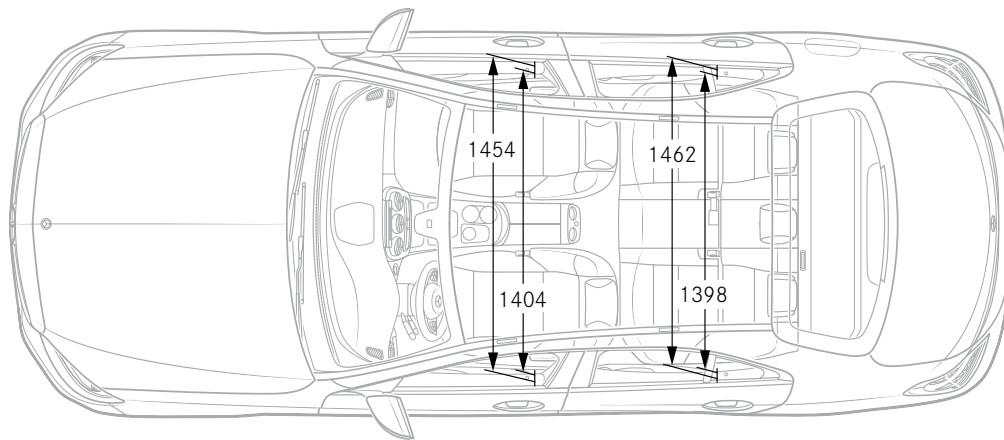
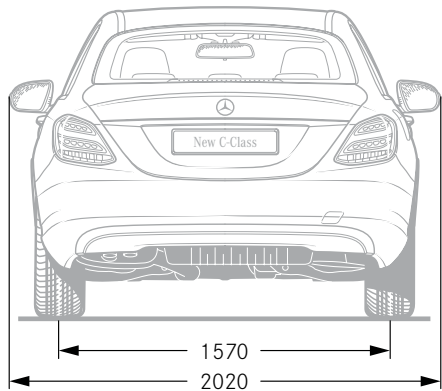
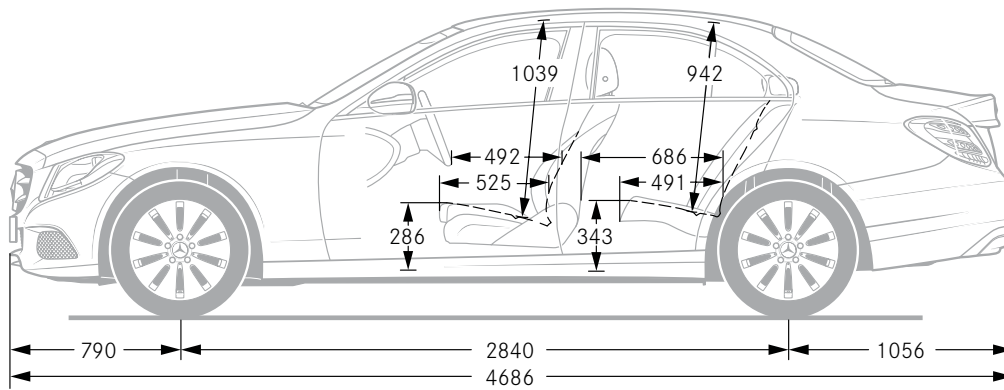
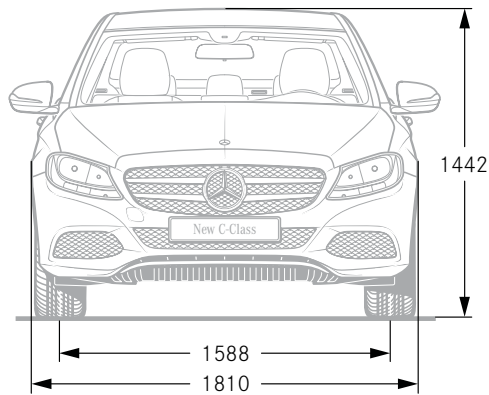

All dimensions in millimetres. The dimensions shown are mean values and apply to standard-specification, unladen vehicles. *Valid only for C200, C220 CDI.

Technical data

	C 200	C 220 CDI	Mercedes-AMG C 63 S
Arrangement/no. of cylinders	Inline / 4	Inline / 4	V/8
Total displacement (cc)	1991	2143	3982
Rated Output (kW (hp) @ rpm)	135 (184) @ 5500	125 (170) @ 3000 - 4200	375 (510) @ 5500-6250
Rated Torque (Nm @ rpm)	300 @ 1200-4000	400 @ 1400 - 2800	700 @ 1750 - 4500
Approx. top speed (km/h)	235	233	250
Acceleration 0 - 100 kmph (s)	7.3	7.4	4.0
Tyres/wheels	225/50 R 17	225/50 R 17 and 225/55 R16	245/35 R19 and 265/35 R19
Transmission	7G-TRONIC PLUS	7G-TRONIC PLUS	AMG SPEEDSHIFT MCT 7-speed sports
Fuel type	Petrol	Diesel	Petrol
Length (mm)	4686	4686	4756
Width (mm)	1810	1810	1839
Height (mm)	1442	1442	1426
Wheelbase (mm)	2840	2840	2840
Kerb weight (kg)	1545	1655	1730
Perm. GVW (kg)	2030	2135	2180
Luggage compartment capacity (l)	480	480	435
Turning circle diameter (m)	11.22	11.22	11.29

*Please read the disclaimer.



Service

The luxurious experience of driving a Mercedes-Benz is converted into a fulfilling ownership experience with a range of exclusive services and special programmes.

Cost of Ownership

There has been a paradigm shift in the buying preferences of Indian consumers over the years, even for the luxury products. The purchase decision not only dwells around cost of acquisition but also the total 'Cost of Ownership' (COO). Amongst the key components of COO in cars are the routine service jobs and the unplanned repair expenses post the warranty period. We are now offering highly-affordable Service Packages and Extended Warranty Programmes which are the most competitive packages in its class. All in all, we provide you with a controlled Cost of Ownership while you benefit from the legendary Mercedes-Benz service quality.

Experience complete peace of mind when you drive the Star

STAR CARE programme offers peace of mind drive for you during warranty period and beyond. While our cars are covered for warrantable repairs up to 3 years without any mileage limitations, as standard, you can also buy STAR CARE Plus programme, offering 4th year extended warranty. Additionally, the programme enhances the resale value of your car.

STAR EASE Service Package gives you the freedom to relax behind the wheel and puts your mind at ease with its range of unique benefits such as defined cost of maintenance and priority handling. STAR EASE Comprehensive package covers essential jobs related to periodic service (viz. oil, filters, consumables, etc.) along with coverage for brake pads, brake discs, wiper blades and wheel alignment & balancing, for a contracted period. For further details on products and pricing, please contact your nearest Mercedes-Benz dealer.

On-Road Assistance Programme

As part of our ongoing commitment to you, Mercedes-Benz On-Road Assistance is designed to enhance your overall Mercedes-Benz ownership experience by providing you with 24-hour On-Road Assistance. Mercedes-Benz is the only Luxury car manufacturer to offer round-the-clock On-Road Assistance for 3 years from purchase of vehicle as a standard offering. Peace of mind motoring – guaranteed.



Extended Warranty that guarantees complete peace of mind



The maintenance of your Star is just as peaceful as driving it



Always at your service

Conditions apply.

India's Largest Luxury Car Network

57

It takes a keen sense of responsibility to provide the Best. Our large network is spread across the country in 39 cities with 78 outlets and is still growing. With world-class showrooms, state-of-the-art workshops and highly skilled personnel, experience the best wherever you go.



DEALER CONTACT:

NORTH & EAST:

BHUBANESWAR:
Tristar Motors: 0-7852944100

CHANDIGARH:
Joshi Autozone: 0172-5050500
Panjab Motors: 0172-4290000

DELHI:
Patel Auto Services, Rajendra Place:
011-47626262/0-9810081048

T & T Motors, Mohan Co-operative,
Mathura Road: 011-66574300/330
Rajouri Garden: 011-66574400/430

GHAZIABAD:
Silver Arrows: 0-9718200500

GURGAON:
T & T Motors: 0124-4263060/62

JAIPUR:
T & T Motors: 0141-4300000/05

JAMSHEDPUR:
Tristar Motors: 0-7763815720/
0657-6601601/02

JALANDHAR:
Joshi Autozone: 0181-5004444

KANPUR:
Smart Hoops: 0-8795663300

KARNAL:
Berkeley Motors: 0184-3300000

KOLKATA:
Benchmark Interkrafts: 1800 3000 3310

LUCKNOW:
Smart Hoops: 0522-6004008/9

LUDHIANA:
Joshi Autozone: 0161-5055000

MOHALI:
Panjab Motors: 0172-4290000

NOIDA:
Silver Arrows: 0-9999200500

WEST:

AHMEDABAD:
Benchmark Cars: 0-9377662000

AURANGABAD:
B. U. Bhandari: 0-8605121333/
0240-6452601/02

BHOPAL:
Benchmark Cars: 0-9098233233

GOA:
Counto Motors: 0832-2415122

INDORE:
Benchmark Cars: 1800-3000-8844

KOLHAPUR:
B. U. Bhandari: 0231-2661422/
0-8380093555

MUMBAI:
Auto Hangar, Prabhadevi: 022-67434362/63
Auto Hangar, Andheri: 022-67106660/61

Metro Motors, Auto Hangar division
Hughes Road: 022-66123500/11
Shaman Wheels, Off BKC: 022-24228787

NAVI MUMBAI:
Shaman Wheels: 022-24228787

NAGPUR:
Auto Hangar: 0-9223540191 /
07104-238180/1/2/3

NASHIK:
Indisch Motoren: 0253-6645555

PUNE:
B. U. Bhandari, Baner: 020-67212129
Pune City Showroom: 020-67212131

RAJKOT:
Benchmark Cars: 0-9377750050

RAIPUR:
Auto Hangar: 0771-6537801/0-8518887155

SURAT:
Benchmark Cars: 0-9377660066

VADODARA:
Benchmark Cars: 0-9377390001

SOUTH:

BANGALORE:
Sundaram Motors: 080-22070720/21

Akshaya Motors, Mysore Road:
080-22966300, 0-9066030989

Akshaya Motors, Koramangala:
080-22966296, 0-9019326026

CALICUT:
Bridgeway Motors: 0495-30 55555

CHENNAI:
Trans Car: 044-40200300
Titanium Motors: 044-66498080/8181/8282

COIMBATORE:
Sundaram Motors: 0422-2452020

COCHIN:
Rajasree Motors:
0484-2706332/2706432/2706134
2607027/37/47

HYDERABAD:
Mahavir Motors: 040-43403004

MADURAI:
Sundaram Motors: 0452-2320433/
0-9500966946

MANGALORE:
Sundaram Motors: 0824-2214833/2215833/
0-9008442155

TRIVANDRUM:
Rajasree Motors: 0471-2380377/
0-9846547551

VIJAYAWADA:
Mahavir Motors: 0866-2082559/
0-9885303004

MERCEDES-BENZ CERTIFIED PRE-OWNED CARS:

BANGALORE:
Akshaya Motors: 0-9019944044
Sundaram Motors: 080-22070746/
0-9880662051

CHANDIGARH:
Joshi Autozone: 0-9878941930/ 0172-
5050500/510

CHENNAI:
Transcar: 0-9841049994

DELHI:
T&T Motors, Mathura Road: 0-9711774424
T&T Motors, West Delhi: 0-9711112243

GHAZIABAD:
Silver Arrows: 0-9718200500

HYDERABAD:
Adishwar: 0-7799633004

KOCHI:
Rajasree Motors: 0-9846547311

MOHALI:
Panjab Motors: 0172-4290000

MUMBAI:
Autohangar India: 0-9223546204,
0-9223547099

Shaman Wheels: 0-9619023450/ 022-
69543333

PUNE:
B U Bhandari: 020-67212172/0-8605118555

AMG PERFORMANCE CENTERS:

BENGALURU:
Sundaram Motors: 080-22070720/21

DELHI:
T&T Motors: 011-66574309

HYDERABAD:
Mahavir Motors: 0-9885033004/
0-9885653004

MUMBAI:
Auto Hangar: 022-67434360/61/65

PUNE:
B.U. Bhandari: 020-67212131/0-8554055555

Our national toll-free no.:

1800 102 9222

One Call. All Answers.

For a complete list of
Mercedes-Benz outlets,
please explore the dealer locator tab on
www.mercedes-benz.co.in

Mercedes-Benz India Private Limited: E-3, MIDC Chakan - Phase III, Chakan Industrial Area, Kuruli & Nighoje, Tal: Khed, Pune - 410 501 (India)
Toll free No.: 1800 102 9222. e-mail: customerconnect@daimler.com, **website: www.mercedes-benz.co.in**

Please note: This brochure is intended for general information, description and illustration of the Product including optional functions and equipment and may not be specific to a Product since specification of a product may change from time to time. Optional features, functions and equipment etc. may not be present in the Standard or Variant Product or Special Edition Product. Further, Standard specifications of a product may also vary from time to time. Colours may differ from those shown in pictures in the brochure, owing to printing. Mercedes-Benz India reserves the right to make changes, at any point of time, without prior notice, in design, colours, materials, components, equipment, specifications, features, functions, make and models etc. The information given in this brochure shall be regarded as accurate at the time of going to print and may vary thereafter due to any developments or any other reason. Interested parties should confirm with the Authorised Dealer about the correct specification of the product they desire to purchase. For the latest authentic information and updates, kindly contact your nearest Authorised Dealer.

All title, ownership rights and intellectual property rights in and relating to this brochure / magazine or publication material or any copies thereof including but not limited to copyright, logos, names, trademarks, service marks, design, text, images, links, concepts and themes are owned by Daimler AG and/or its subsidiaries collectively or used under authorised license by the Daimler AG. Any reproduction, transmission, publication, performance, broadcast, alteration, license, creation of derivative works or other use in whole or in part in any manner without the prior written consent of the Daimler AG is strictly prohibited.

Month of going to press: August, 2015. Mercedes-Benz cars: The C-Class meets Bharat Stage IV equivalent emission norms.

CIN - U34102PN1994PTC083160